

# Test Certificate

Title

## Thermocouple SEV-Lance



### Note

This test certificate is intended for qualified personnel only.



**Tick respectively fill out the following required boxes (after it is carried out).**

1. Distance of welding clips is between 20-100 mm  
 **Ok**
2. Visual investigation of each clip weather they have cracks after spot welding  
 **Ok**
3. Thermocouple bending is protected efficiently  
 **Ok**
4. Sleeve nut must be reachable after welding the bow  
 **Ok**
5. All edges along the routing are rounded  
 **Ok**
6. Welding clips keeps TC bending in tension so that TC can not move backwards out of sleeve  
 **Ok**
7. The thermocouple is in the hole-bottom face  
 **Ok**

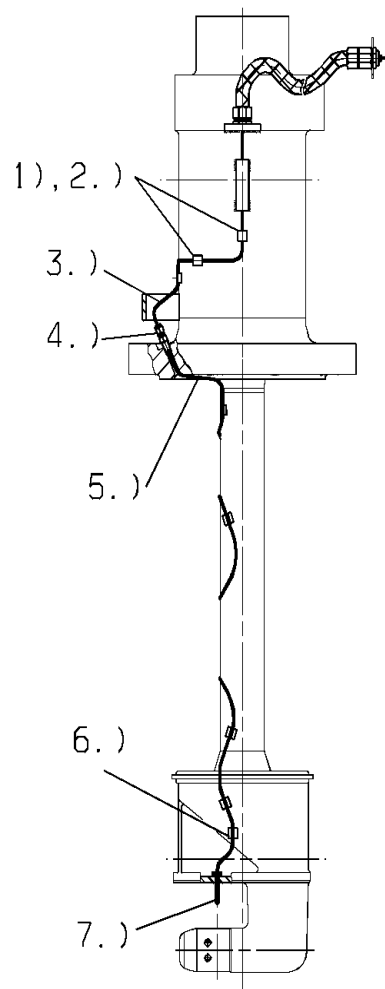

Name
Signature

Dept. Document No.	Type	Rev. Released	Lang.	Status
9560 HTCT433200	FA	B 2006-12-18	EN	Approved

<b>Test Decision</b> <small>(as required/acc. to specification)</small>	<input type="checkbox"/> <b>Accepted*</b> <b>NC-Report*</b>	<input type="checkbox"/> <b>Rejected*</b> <b>Rework*</b>	Unit / System Name		
NCR No.*	Part Idnr		Part Text	Quantity	
Checked by**	Power Station Designation	Rev.	I & T Plan ID		
Approved by**	Material Test No.	Rev.	Test Step	Order No.	
Authority / Customer**	Factory Order		Document No.		
		Sheet No. <b>1</b>	No. of Sh. <b>1</b>	<b>HTCT433200</b>	
					Rev. <b>B</b>

\* Mark/Fill in if applicable    \*\* Name / dept. / date / initials